

Modeling Methods and Test Verification of Root Insert Contact Interface for Wind Turbine Blade

*Li Hui, Wang Tongguang**

Jiangsu Key Laboratory of Hi-Tech Research for Wind Turbine Design,
Nanjing University of Aeronautics and Astronautics, Nanjing 210016, P. R. China

(Received 22 September 2015; revised 16 November 2015; accepted 5 January 2016)

Abstract: Two modeling methods of the root insert for wind turbine blade are presented, i. e., the local mesh optimization method (LMOM) and the global modeling method (GMM). Based on the optimized mesh of the local model for the metal contact interface, LMOM is proposed to analyze the load path and stress distribution characteristics, while GMM is used to calculate and analyze the stress distribution characteristics of the resin layer established between the bushing and composite layers of root insert. To validate the GMM, a tension test is carried out. The result successfully shows that the shear strain expresses a similar strain distribution tendency with the GMM's results.

Key words: root insert; modeling methods; mesh optimization; contact interface; tension test

CLC number: TK89 **Document code:** A **Article ID:** 1005-1120(2016)01-0009-07

0 Introduction

Currently, the connections of the wind turbine blade root mainly adopt T-bolt and root insert. T-bolt modeling and analysis method has been mastered by many domestic research institutions. Li^[1] used ANSYS to establish the finite element analysis model of T-bolt. The stress analysis and strength check were carried out for fiber reinforced polymer (FRP) and bolts of root connection in order to guide the design, optimization and material selection for T-bolt. Pan^[2] and his group focused their research on the method for finite element (FE) modeling of complicated layered structures. In consideration of the characteristics of repeated layers in root structure for wind turbine blade, the sub-laminate method was introduced for calculating equivalent stiffness. The FE model of root structure was established while it was treated as unique material, and the effect of loads on boundary conditions is also discussed, as well as the contact states between nuts and

holes.

However, root insert technique has still been in the product design and test verification phase for domestic wind power research institutes so far. The key analytical methods are monopolized by the minorities of foreign research institutions who own public patents related to the configuration, design and process manufacturing method. In 1990, the connection of root insert was firstly published by Fayette Manufacturing Corporation which created the precedent of the root insert configuration design^[3]. In 2009, GAMESA pointed out that the bushing and composite layers of root insert had two forms of double shear joint^[4-5]. In 2010, VESTAS claimed that the length of bushing design could be changeable^[6]. In 2014, Li-anZhong proposed a method to manufacture root insert bushings for wind turbine blade by pultrusion process^[7].

In recent years, with the rapid development of large wind turbines, there has been a growing trend of large blades. T-bolt due to its own limi-

*Corresponding author, E-mail address: tgwang@nuaa.edu.cn.

tations is gradually replaced by root insert. However, there are few publicly available resources related to the technical research of root insert^[8]. Therefore, it is the key technology to master the accurate modeling and calculate analysis for root insert of blade design. There is a possibility that the efficient and accurate modeling and simulation for root insert may provide more accurate simulation data for the strength test which needs long circle and high price, or can even replace it.

1 Coulomb Friction Contact

According to the root insert of wind turbine blade, the nonlinear contact of the contact interfaces is analyzed using the Coulomb friction model. Mechanics define the contact as a complex problem, because the boundary conditions are highly nonlinear. The movement of the objects should be traced accurately, and the interactions of those should be traced as well after the contact. The two contact objects must fit the no penetration constraint condition, that is

$$\Delta u_A \cdot n \leq D \quad (1)$$

where Δu_A is the incremental displacement vector of point A , n the unit normal vector, and D the contact distance tolerance.

Coulomb friction is widely used. The Coulomb friction contact model is expressed in Eq. (2)

$$\sigma_{fr} \leq -\mu \sigma_n t \quad (2)$$

where σ_n and σ_{fr} denote the normal stress and the tangential friction stress of contact node, respectively. μ is the friction coefficient, and t the tangential unit vector in the direction of the relative slipping velocity.

The Coulomb friction is a highly nonlinear property that relies on the normal force and the relative sliding speed, it is an implicitly function of velocity and displacement increment. The value consists of two parts: one is the contribution of the tangential friction force, and the other is the contribution of the system stiffness matrix.

2 Mesh Optimization and Metal Contact Interface Analysis

Modeling analysis and test model of this paper are selected from teeth-bushing and cylinder bolt which are widely used in wind turbine engineering at present. Fig. 1 shows the integral component type and the model relationship.

2.1 Optimization of mesh topology

To discuss the load path of bushing and the characteristics of contact stress, two-dimensional (2D) cross-sectional symmetrical model is used because the components of the root insert are complicated. The model is divided into three main metal member, called the bolt, bushing and flange. Mesh topology optimization model is built for the main load path of contact interface, which can be an effective way to avoid the stress concentration caused by the mesh quality, and improves the nonlinear accuracy of the contact area.

To simplify the structure reasonably, high-order accurate topology optimization with 1 to 2 mesh is applied to contact areas manually (Fig. 2), and a few automatic meshes are acted on non-power transmission parts. Three load cases are carried out on the 2D model which are preload, preload and tension, preload and compress, using the Coulomb friction contact model. Setting the coefficient of friction as 0.2, the characteristics of the shear stress distribution in the metal contact interface are calculated.

2.2 Analysis of metal contact interface

2.2.1 Flange-bushing contact stress analysis

The distribution stress curves of the Cauchy stress and the contact normal stress in the flange and bushing contact interface elements are calculated under three load conditions. The abscissa is shown in Fig. 2, the correspondence of the flange-bushing contact elements are from top to bottom. Fig. 3 shows that the distribution trends of Cauchy stress in the contact interface area increase from the inside out, and stress distribution

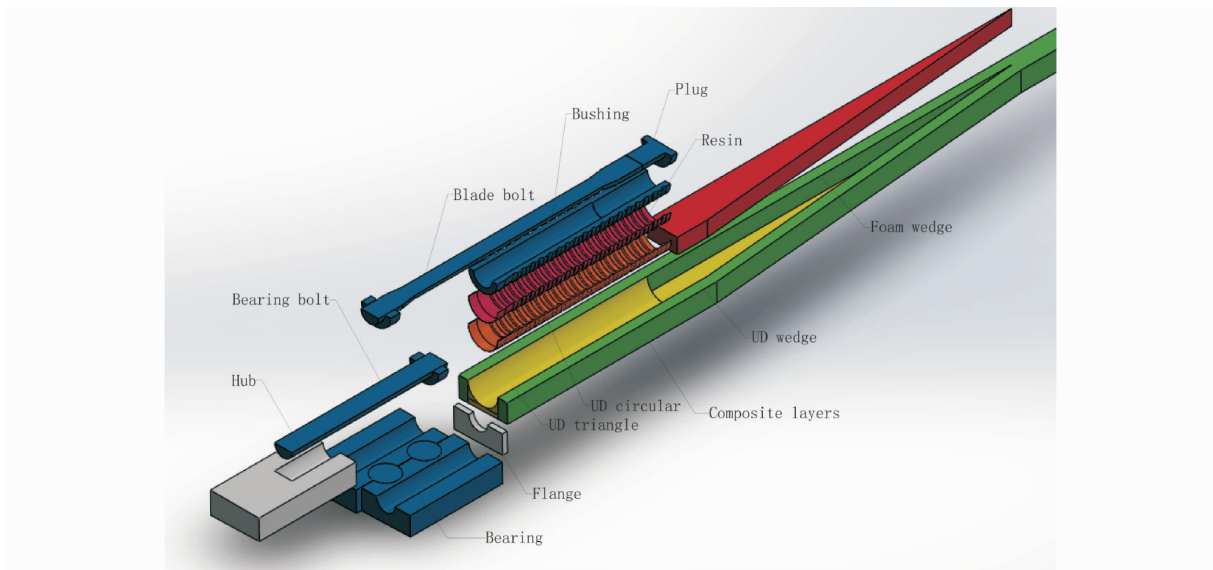

Fig. 1 Integral component type and model relationship of root insert

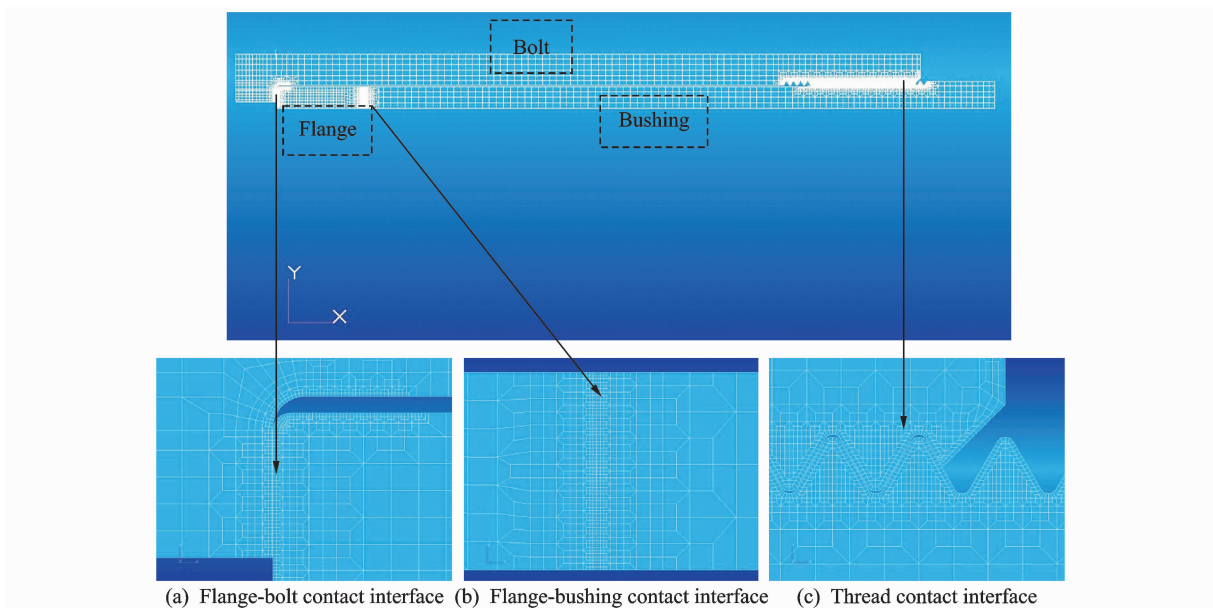

Fig. 2 Topology optimization of metal contact interface

curve is consistent with the stress contour. The external force is transferred from the flange-bushing contact surface through bushing, so the tension unloads the bushing, while the compress unloads the bushing. The force transferring path between the flange and bushing is verified by the three Cauchy stress curves.

2.2.2 Flange-bolt contact stress analysis

Fig. 4 shows the distribution stress curve of the flange-bolt contact interface elements. The abscissa is shown in Fig. 2, the correspondence of

the flange-bolt contact elements are from top to bottom. The external force is transferred from the flange-bushing contact surface through bushing, the flange-bolt contact interface stress levels of the three load conditions are substantially the same. Stress concentration appears in the corner, and the local stress exceeds the material yield strength, therefore, the material is set to elastic-plastic and recalculated. Fig. 5 shows the stress distribution of the flange-bolt contact section, which indicates that the elastoplastic modeling

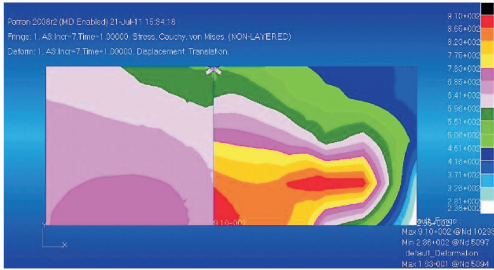
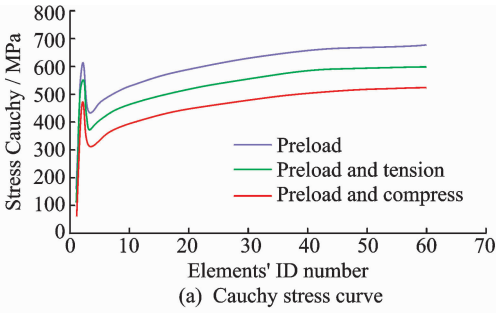

Fig. 3 Cauchy stress curve and stress contour of contact interface between flange and bushing

can improve the stress concentration in the corner to a certain extent after using the characteristics of the elastoplastic material. Got to this point, the contact element generates plastic deformation, and the contact Cauchy stress and normal stress level are within the material yield strength range.

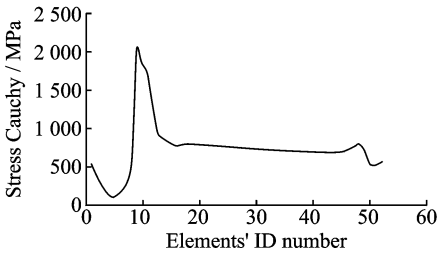

Fig. 4 Cauchy stress curve of contact interface between flange and bolt

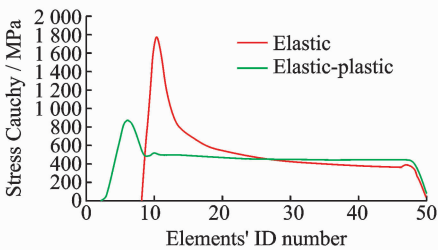

Fig. 5 Normal stress distribution of contact interface between elastoplastic flange and elastoplastic bolt

2.2.3 Thread analysis

Fig. 6 shows the normal stress distribution of the threads. The abscissa is shown in Fig. 2, and the correspondence of the thread contact elements are from left to right. Fig. 7 shows the normal stress distribution results of the first five threads, and the stress distribution of the thread contact elements is greatly influenced by the contact analysis of the thread section, which presents obvious fluctuation. The first thread stress is the largest, and the rest is in a descending order. The fifth thread has fallen about 50%, so it is important to focus on the load capacity of the first 4—5 thread in calculation and analysis.

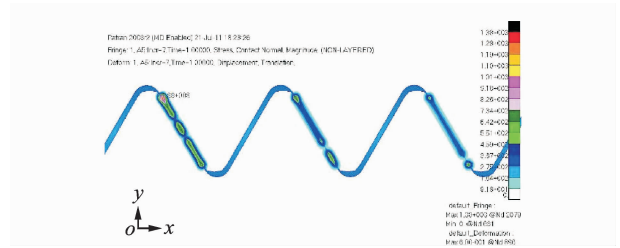

Fig. 6 Normal stress contour of threads contact interface

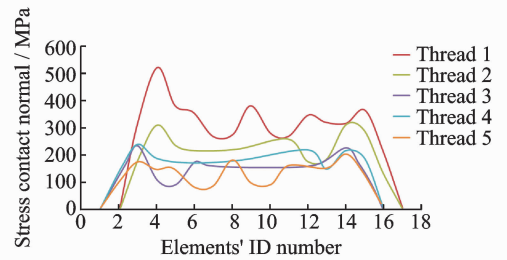

Fig. 7 Normal stress of threads contact interface

Above all, mesh topology of the metal contact interface for root insert is optimized, and the analysis accuracy of the contact interface is improved. In the case of uploading the preload and external force on the flange-bushing, flange-bolt and thread, using the Coulomb friction contact model, the load path of root insert is given, and the distribution characteristics of the Cauchy stress and normal stress in the metal contact interface are also calculated. Based on the nonlinear contact analysis, though the interface is optimized by mesh topology, the stress distribution is still not strictly continuous, which may be associated

with the nonlinear force of the contact surface.

3 FE Modeling and Shear Stress Analysis of Contact Interface Between Bushing and Composite Layers

Section 2 mainly discusses the mesh optimization modeling and contact analysis of the metal contact interface for root insert, while the Section 3 sets the multiple complex contact constraint for the entire root insert. The relationships of the constraint components are shown in Table 1. There are eleven pairs of constraints, using the Coulomb friction model with the friction coefficient 0.2.

Table 1 Multiple complex contact constraints of integral root insert

ID	Contact component	
1	Bushing	Plug
2		Resin
3	Composite layers/Bushing/ Resin/UD circular/ UD triangle/UD wedge	Flange
4	Flange	Bearing inner ring
5	Blade nut	Bearing inner ring
6	Bearing outer ring	Hub nut
7		Hub
8	Bearing ball top	Bearing inner ring
9		Bearing outer ring
10	Bearing ball bottom	Bearing inner ring
11		Bearing outer ring

To calculate the interfacial shear stress between bushing and composite layers, considering the form of manufacturing process, an isotropy resin layer is established on the surface of the composite layers. The thickness of the layer is 0.1 mm, the elastic modulus of the resin layer 3 000 MPa, and the poisson ratio 0.3 (Fig. 8). Using the Coulomb friction model, the contact is analyzed with both preload and tension loading at the same time. After the simulation, the in-plane shear stress of resin layer is extracted (Fig. 9) which shows that the stress is distributed evenly.

Along the spanwise direction of blade root, the in-plane shear stress in the middle of the resin

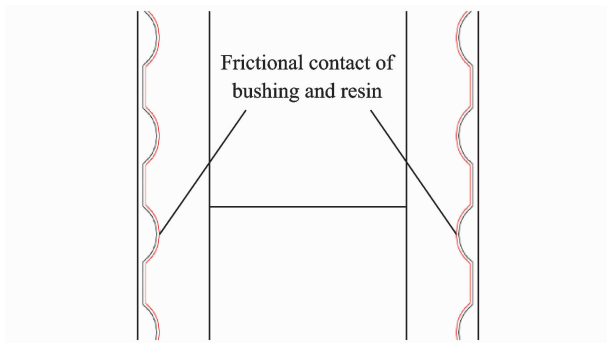

Fig. 8 Resin modeling between bushing and composite layers

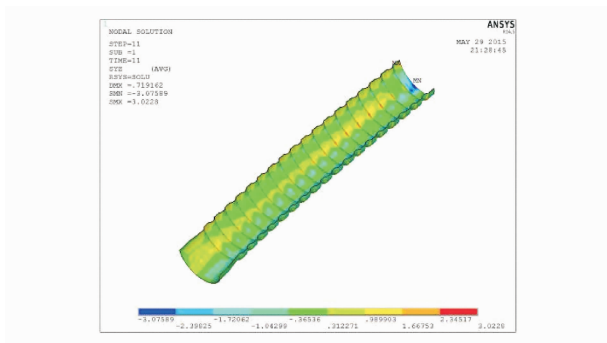

Fig. 9 In-plane shear stress contour of resin layer

level is extracted, and the distribution of the values is shown in Fig. 10. The distribution of the in-plane shear stress along the spanwise direction approaches a balance. A certain volatility exists, which is caused by the teeth shape design of the bolt. The strength analysis assumption of the connection part is mentioned by the universal wind turbine design standard GL2010^[9]. It believes that, both in the blade web-shell joints and the blade leading-trailing edge joints, the shear stress distribution of joints could be seemed as a steady shear stress distribution. The root contact is not mentioned and the contact interface of the root insert is also not involved in GL2010 because the analysis stresses of which are not completely steady state distribution.

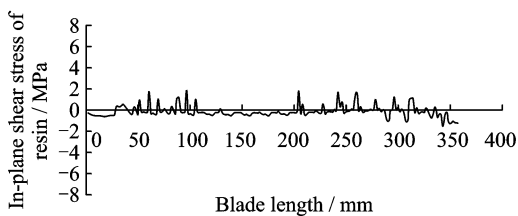

Fig. 10 In-plane shear stress curve of resin layer

4 Tension Test of Root Insert

An experiment of root insert integral component is shown in Figs. 11. The strain gauges are embedded equidistantly along the longitudinal direction in the contact interface between bushing and composite layers, and the distance of each is 50 mm. Local strain is measured in the test sections at six locations by the use of MTS to load tension force (Fig. 12). The test begins with the loading started and ended when the bolt is pulled out. During the test the force-time curve of root insert is monitored, and the strain is also recorded.



Fig. 11 Manufactured products of root insert

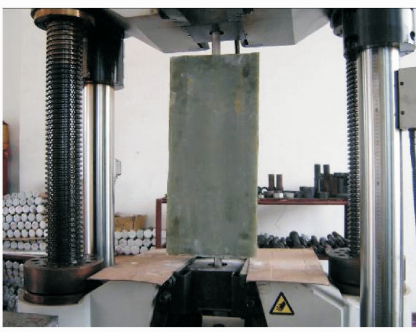

Fig. 12 Tension test of root insert

The two-way tensile loading is used in the experiment. The calculation model of the root insert and the analysis method is discussed in chapter 3. Fig. 13 shows the strain distribution trends of the experimental result when the bolt is pulled out and the calculation results are obtained by the GMM's FE model. It is proved to be a similar strain distribution to a certain extent. Therefore, the method of modeling and analysis by FEM

seems to be very promising and can be used in root insert design for wind turbine blade. Nevertheless, there is a certain difference of the stress distribution near the loading section between the experimental value and calculated value because of the influence by loading boundary condition.

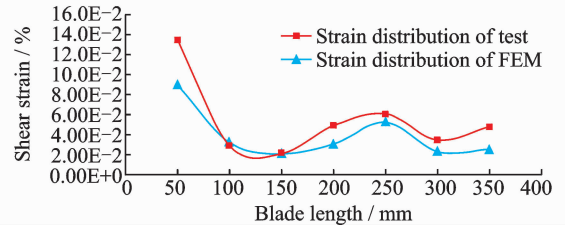

Fig. 13 Strain distribution of interface between bushing and composite layers

5 Conclusions

LMOM and GMM are successfully simulated and tested to analyze the root insert interface for wind turbine blade according to the Coulomb friction contact model. LMOM analyzes the load path of the root insert and the stress distribution characteristics of the metal contact interface by mesh optimization. GMM calculates and analyzes the stress distribution characteristics of the isotropic resin between the bushing and composite layers on the premise of multiple complex contact constraints. The GMM results are tested by the tension test of the root insert integral component which shows a similar strain distribution tendency. This provides a good modeling and analysis basis for the calculation and simulation of the root insert for wind turbine blade. LMOM and GMM provide a good modeling and analysis basis for the calculation and simulation of the root insert for wind turbine blade. Although a lot of improvement can be made in LMOM and GMM, we see a possibility that those models can be developed to give accurate analysis predictions, which makes root insert test become unnecessary.

Acknowledgements

This work was supported jointly by the National Basic Research Program of China ("973" Program) (No.

2014CB046200), the National Science Foundation of Jiangsu Province (No. BK2014059), the Priority Academic Program Development of Jiangsu Higher Education Institutions, and the National Natural Science Foundation of China (No. 11172135).

References:

- [1] LI Donghai. Finite element analysis of the root connection for wind turbine blade[J]. FRP, 2010 (4): 1-5.
- [2] PAN Yanhuan. Finite element modeling of wind turbine blade root[J]. Journal of North University of China: Natural Science Edition, 2010, 31(4): 429-432.
- [3] ECKLAND J E, FREROTTE J V. Wind turbine blade attachment methods[P]. US4915590, 1999.
- [4] AROCENA DE LA RUA I, PASCUAL E P. Blade insert; US2009/0324417A1[P], 2009-12-31.
- [5] AROCENA DE LA RUA I, PASCUAL E P. Blade insert; US2009/0324420A1[P], 2009.
- [6] VRONSKY T, HAHN F. Wind turbine rotor blade; WO/2010/052487A2[P]. 2010-05-14.
- [7] HUANG Huixiu, WANG Zhiwei, et al. A method to manufacture root insert bushings for wind turbine blade by pultrusion process; CN103909662A [P]. 2014-07-09.
- [8] SA Haoliang. Strength analysis method and experimental study on root bolt of wind blade in pre-burying bolt sleeves[D]. Wuhan: Polytechnic University, 2013.
- [9] GL2010 IV-Part 1. Guideline for the certification of wind turbines[S]. Hamburg: Germanischer Lloyd, 2010.

Ms. **Li Hui** is a Ph. D. candidate of Nanjing University of Aeronautics and Astronautics (NUAA). She received her B. S. degree in civil engineering from NUAA in 2008 and M. S. degree in fluid mechanics from NUAA in 2011. Currently, she is working on the design of wind turbine blades in fluid mechanics.

Dr. **Wang Tongguang** is the Director of Jiangsu Key Laboratory for Wind Turbine Design at NUAA. He was designated as the Chief Scientist of the "973 Program" by the Ministry of Science and Technology, China in 2007, and successfully completed the project "Fundamental Study of Large Scale Wind Turbine Aerodynamics". As the Chief Scientist again, he is now in charge of another project of the "973 Program"—"Key Mechanical Issues and Design of Large Scale Wind Turbines". Prof. Wang graduated from NUAA with B. S. degree and M. S. degree in 1983 and 1988, respectively, and he received his Ph. D. degree from the University of Glasgow in 1999 and has been a postdoctoral fellow at the University of Glasgow from October 1999 to August 2001. During this period, he was invited to join in the Wind Turbine Unsteady Aerodynamics Experiment - Blind Comparison, organized by the National Renewable Energy Laboratory (NREL) of USA. His paper "An examination of key aerodynamic modeling issues raised by the NREL Blind Comparison" was awarded The Best Paper Prize by ASME/AIAA in 2002.

(Executive Editor: Zhang Tong)

